



**Scientific Microwave**

AN ISO 9001-2008 CERTIFIED COMPANY

Manufacturers of: Microwave Passive Components  
Instruments & custom made Components etc.

GST NO – 09AXAPS2587H1Z2

## DATA SHEET

**DESCRIPTION – C – BAND STRAIGHT WAVEGUIDE**

**PART NO – SM018W229SW305**

**REF BEL PART NO – 455043890222**

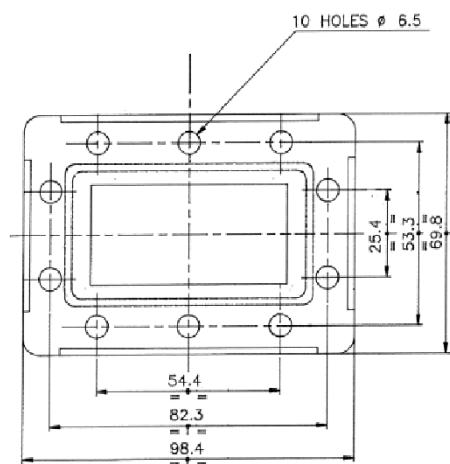
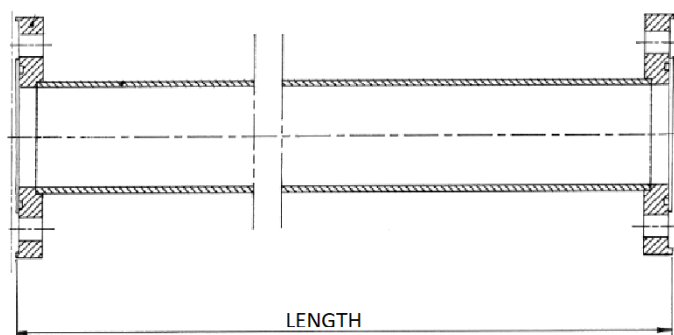

### ELECTRICAL SPECIFICATION –

1. FREQUENCY RANGE: 3.625 to 4.2 GHz
2. VSWR: 1.25 (Max.)
3. INSERTION LOSS: 0.2dB (Max.)

### MECHANICAL SPECIFICATION –

1. WAVEGUIDE SIZE: WR229
2. MATERIAL : BRASS/COPPER
3. FLANGE: CPR229 (GROOVED)
4. FLANGE 2: CPR229 (FLAT)
5. LENGTH: 305mm ± 1mm
6. FINISH: CORROSION TREATMENT
7. WAVEGUIDE COLOUR: PAINTED BLACK  
(OUTER SIDE)

ADDRESS: - PLOT NO 31, LANE NO-4, RAJENDER NAGAR INDL AREA MOHAN NAGAR GHAZIABAD – 201007 U.P.

E-mail: - [info@smwave.com](mailto:info@smwave.com), [scientificmicrowaves@gmail.com](mailto:scientificmicrowaves@gmail.com)

**WEB SITE: - [www.smwave.com](http://www.smwave.com)**